

NEW

PLUS-SV



ELETTROPOMPE
multigriganti



CARATTERISTICHE / CHARACTERISTICS CARACTERISTICAS / CARATERISTIQUES



UTILIZZI - Pompe centrifughe multistadio verticali. Movimentazione di liquidi non carichi nei settori civili, agricoli ed industriali; sistemi di pressurizzazione; irrigazione; acque potabili o con glicole in soluzione; trattamento acque; industria alimentare; riscaldamento e condizionamento; sistemi di lavaggio.

VANTAGGI - Versione monoblocco compatta con ingombri ridotti; estrema silenziosità di funzionamento; ottimo rendimento con una notevole diminuzione dei costi d'esercizio e delle potenze impegnate; economica; cuscinetti motore sovradimensionati per una maggior durata; cuscinetto intermedio guida-albero che garantisce coassialità di rotazione.

CARATTERISTICHE COSTRUTTIVE - Portata fino a 26 m³/h; prevalenza fino a 125 m; pressione massima di esercizio 8 bar ≤ 6 giranti, 14 bar > 6 giranti; temperatura d'esercizio del liquido pompato: da -15 a +90°C; temperatura ambiente max 40°C.

MOTORE - Motore a 2 poli ad induzione; monofase 230V – 50 Hz dotati di protezione termica fino a P2= 1,85 kW; trifase 230/400 V – 50 Hz; isolamento classe F; protezione IP 44.

MATERIALI - Flangie aspirazione/mandata corpo pompa: ghisa; camicia, giranti, diffusori: acciaio cromo-nichel AISI 304; albero: acciaio cromo-nichel AISI 303; supporto motore: ghisa; tenuta meccanica: ceramica-grafite fino a 6 stadi / grafite-carburo di silicio da 7 stadi; cuscinetto intermedio guida-albero: ceramica-carburo di tungsteno; guarnizioni corpo pompa: EPDM.

USES - Multistage vertical pumps. Pumping of clean non-loaded fluids in the domestic, agricultural and industrial sectors; pressurizing systems; irrigation; drinking and glycol water; water treatment; food industry; heating and air conditioning; washing system.

ADVANTAGES - Closed coupled and compact; silent; excellent efficiency that allows a reduction of running cost ad powers; economical; over-dimensioned bearings for longer life of the machines; intermediate shaft guiding stage for concentricity of rotation.

CONSTRUCTION FEATURES - Capacity: up to 26 m³/h; total Head: up to 125 m.; maximum working pressure: 8 bar ≤ 6 impellers. 14 bar > 6 impellers; maximum liquid temperature: from -15 to + 90 °C; ambient temperature: max 40 °C.

MOTOR - 2 pole induction Motor; single phase 230V - 50Hz with thermal protector up to P2= 1,85 kW; three phase 230-400V - 50 Hz; insulation class F; protection degree IP 44.

MATERIALS - Flanged siction pump body: cast iron; flanged delivery pump body: cast iron; shell, impellers, diffusers: AISI 304 chromo-nickel steel; pump shaft: AISI 303 cromo-nichel steel; motor bracket: cast iron; mechanical seal: ceramic-graphite up to 7 stages - graphite-silicon carbide from 6 stages; intermediate shaft guiding stage bush: ceramic-tungsten carbide; pump body gasket: EPDM.

UTILIZACIONES - Bombas centrifugas multietapas verticales. Bombeo de líquidos químicamente y mecánicamente no agresivos en el sector doméstico, agrícola e industria; sistemas de presurización; riegos; agua potable o con glycol; tratamientos del agua; industria alimenticia; calefacción y refrigeración; sistemas de lavado.

VENTAJAS - Versión monobloc compacta con medidas reducidas; extrema silenciosidad de funcionamiento; excelente rendimiento con desminución de los costes de ejercicio y de las potencias; económica; cojinetes del motor sobredimensionados para una mayor duración; cojinete intermedio guía-eje que garantiza la coaxialidad de rotación.

CARACTERÍSTICAS CONSTRUCTIVAS - Caudal hasta los 26 m³/h; prevalencia hasta los 125 mt.; maxima presión de ejercicio 8 bar ≤ 6 rodetes, 14 bar > 6 rodetes; temperatura de ejercicio del liquido bombeado: de -15 a +90°C; temperatura del ambiente max 40°C.

MOTOR - Motor de 2 polos a inducción; monofásico 230v-50hz dotado de protección térmica hasta P2= 1,85 kW; trifásico 230/400v-50hz; aislamiento clase F; protección IP 44.

MATERIALES - Bridas de aspiración/envío cuerpo bomba: fundición; camisa, rodetes, rifusores: acero cromo-níquel AISI 304; eje: acero cromo-níquel AISI 303; soporte motor: fundición; sello mecánico: cerámica-grafito hasta los 6 estadios - grafito-carburo de silicio de los 7 estadios; cojinete intermedio guía-eje: ceramica-carburo de tungsteno; guarniciones cuerpo bomba: EPDM.

UTILISATION - Pompes multicellulaires verticales. Pour le pompage d'eaux propres non chargées pour des applications domestiques, agricoles, industrielles; groupes de surpression; irrigation; eau potable ou solution de glycol; traitement des eaux; industrie alimentaire; chauffage et Climatisation; stations de lavage auto.

AVANTAGES - Version monobloc compact; silencieux; rendement excellent avec une diminution remarquable des coût de fontionnement et des puissance; économique; roulements surdimensionnés et étage de guidage intermédiaire pour une durée de vie prolongée des machines; roulement intermédiaire étage de guidage qui garantie le coaxialité de rotation.

CARACTÉRISTIQUES D'EXÉCUTION - Débit jusqu'à 26 m³/h; hauteur jusque'à 125 m.; pression max. de fonctionnement 8 bar ≤ 6 roues, 14 bar > 6 roues; température du liquide pompé: de -15 à + 90 °C; température ambiante max 40 °C.

MOTEUR - Moteur 2 pôles à induction; monophasé 230 V – 50 Hz avec protection thermique jusqu'à P2= 1,85 kW; triphasé 230/400 V – 50 Hz; isolation en classe F; degré de protection IP 44.

MATERIAUX - Brides corps de pompe: fonte; chemise externe, roues, diffuseurs: acier au chrome-nichel AISI 304; arbre: acier au chrome-nichel AISI 303; support moteur: fonte; garniture mécanique: céramique – graphite jusqu'à 6 étages, graphite - carbure de silicium à partir de 7 étages; douilles étage de guidage intermédiaire: céramique -carbure de tungstène; joint corps de pompe: EPDM.

P 5 S V - 120 / 4 T

P Tipo - Type **PLUS**
5 Portata nominale in m³/h - Nominal flow-rate m³/h
S Idraulica in acciaio inox - Stainless-steel hydraulic
V Verticale - Vertical
120 Potenza nominale in HPx100 - Nominal Power HPx100
/
4 n° giranti - no. of impellers
T Trifase - Three-phase

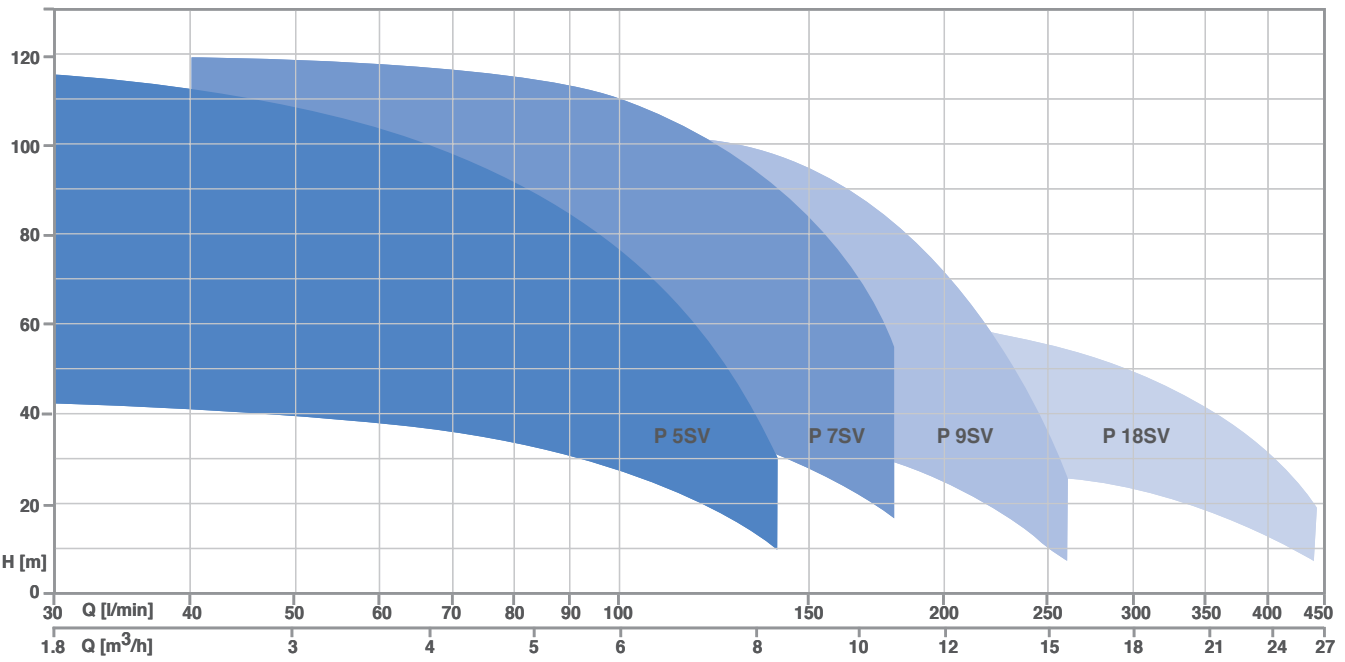

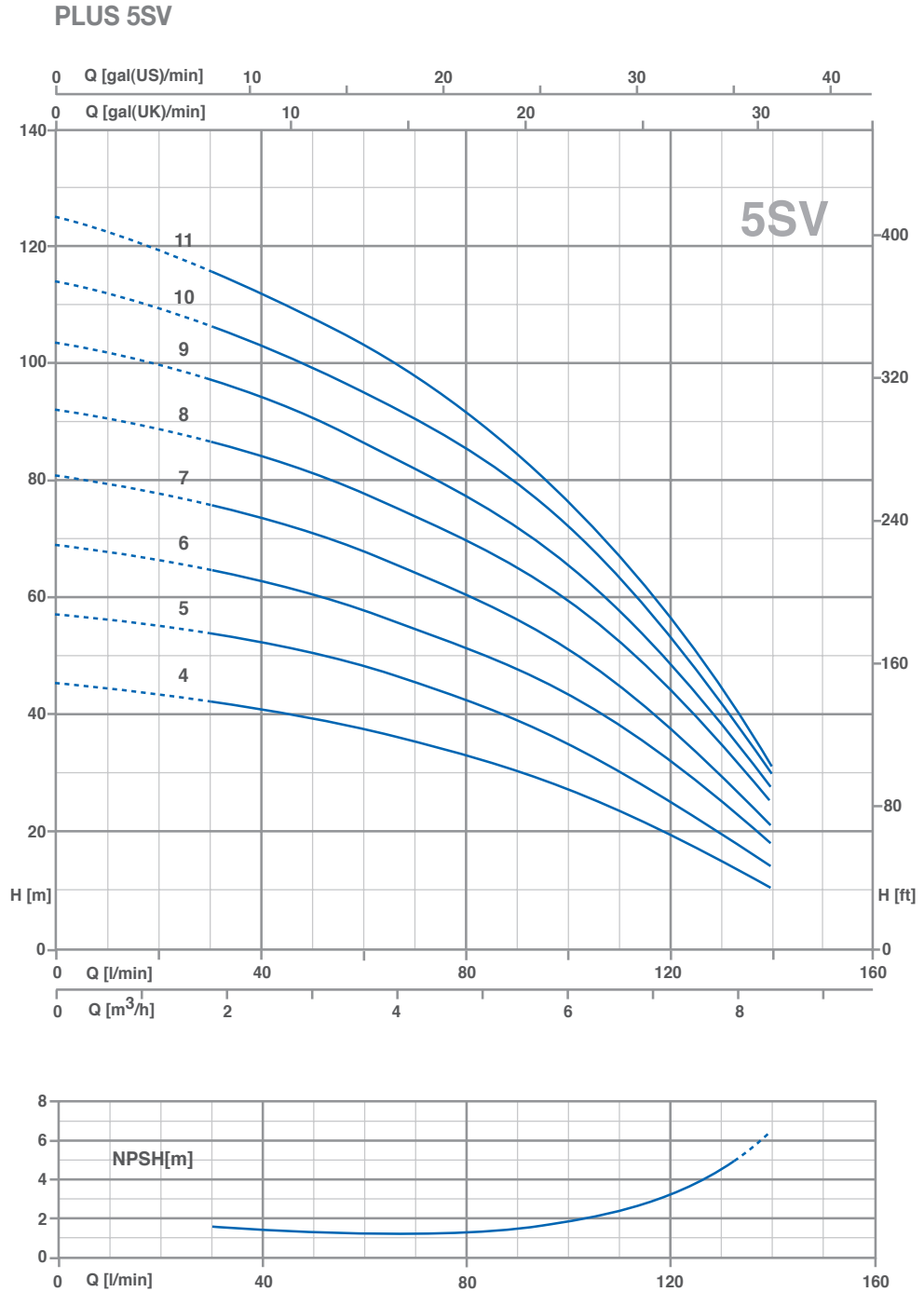

Dati tecnici / Technical data / Datos técnicos / Données techniques

TIPO / TYPE / MODELO / MODÈLE		P2		P1 (kW)		AMPERE		Q (m³/h - l/min)							
1~	3~	(HP)	(kW)	1~	3~	1~	3~	0	1.8	2.4	3.6	4.8	6	7.2	8.4
								0	30	40	60	80	100	120	140
								H (m)							
230 V - 50 Hz	230 / 400 V - 50 Hz					1x230V 50Hz	3x400V 50Hz								
P 5SV-120/4	P 5SV-120/4 T	1.2	0.9	1.09	1.03	4.9	2.4	45.5	42.2	40.1	37.2	32.9	27.4	19.8	10.4
P 5SV-150/5	P 5SV-150/5 T	1.5	1.1	1.39	1.31	6.5	2.7	57.2	53.4	51.7	47.6	42.3	35.2	25.7	14
P 5SV-180/6	P 5SV-180/6 T	1.8	1.3	1.63	1.55	7.3	3	68.9	64.4	62.3	57.5	51.5	43.5	32.6	18.1
P 5SV-200/7	P 5SV-200/7 T	2	1.5	1.94	1.77	8.7	3.3	81	75.5	73	67.4	60.3	51	38.6	21
P 5SV-250/8	P 5SV-250/8 T	2.5	1.85	2.2	2.07	10.1	4	92.1	86.5	84	77.8	70.1	60	45.5	26
P 5SV-280/9	P 5SV-280/9 T	2.8	2.1	2.45	2.27	11	4.2	103.4	96.7	93.5	86	77.1	65.6	48.7	27.6
P 5SV-300/10	P 5SV-300/10 T	3	2.2	2.67	2.57	11.9	4.7	114.2	106.4	102.9	95.2	85.2	72	53.3	30
P 5SV-350/11	P 5SV-350/11 T	3.5	2.57	2.85	2.76	12.9	4.9	125.1	115.7	111.8	102.6	91.6	77.1	57.1	30.7

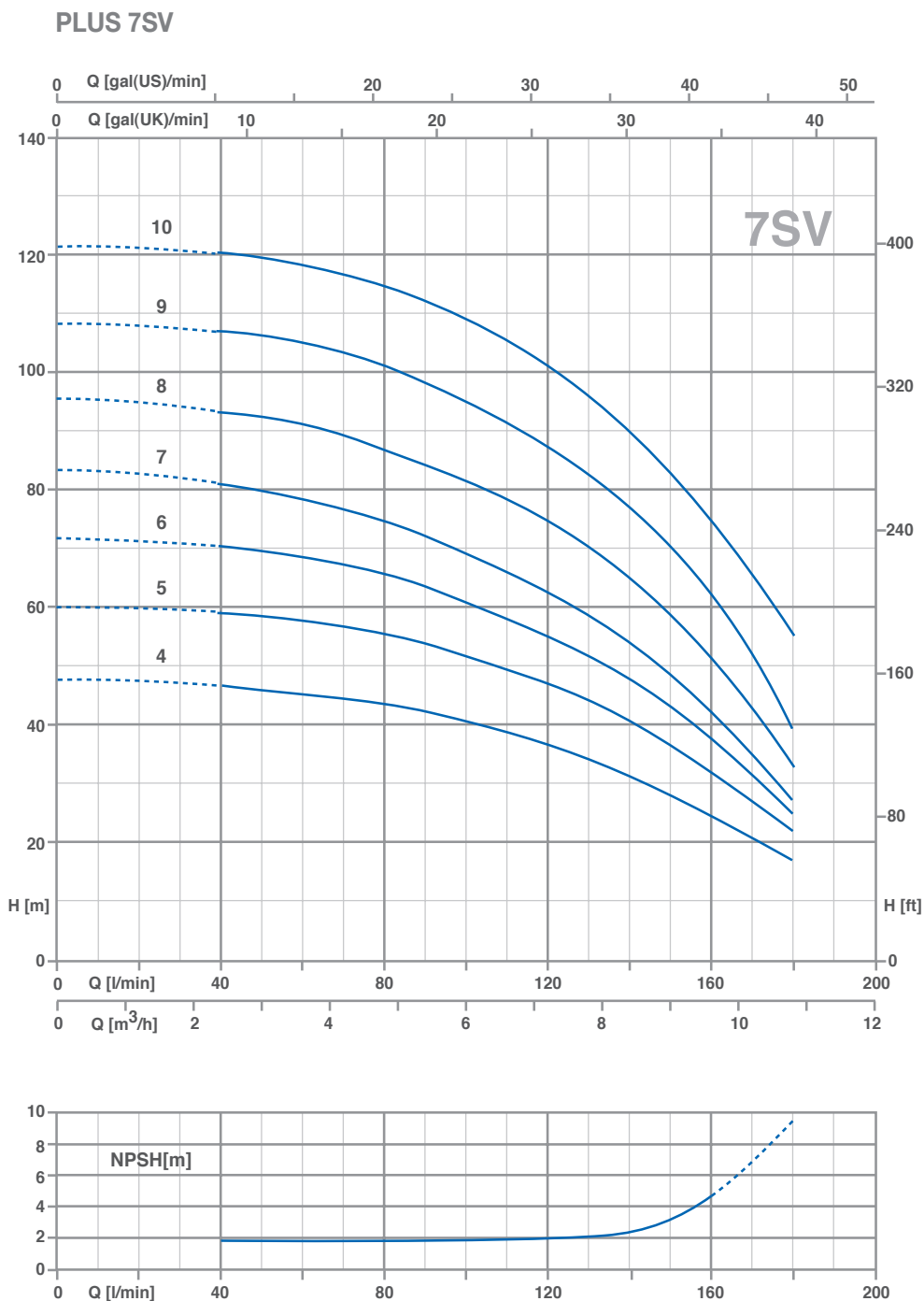

Dati tecnici / Technical data / Datos técnicos / Données techniques

TIPO / TYPE / MODELO / MODÈLE		P2		P1 (kW)		AMPERE		Q (m³/h - l/min)											
1~	3~	(HP)	(kW)	1~	3~	1~	3~	0	2.4	3.6	4.8	6	7.2	8.4	9.6	10.8			
								0	40	60	80	100	120	140	160	180			
230 V - 50 Hz		230 / 400 V - 50 Hz				1x230V 50Hz		3x400V 50Hz		H (m)									
P 7SV-180/4	P 7SV-180/4 T	1.8	1.3	1.69	1.62	7.7	3.1	48.0	46.3	45.7	43.6	40.4	36.4	31.4	25.0	17.2			
P 7SV-250/5	P 7SV-250/5 T	2.5	1.85	2.19	2.05	10.2	4.1	60.3	59.0	58.2	55.7	52.2	47.4	41.3	33.5	22			
P 7SV-300/6	P 7SV-300/6 T	3	2.2	2.53	2.44	11.4	4.8	72.5	70.5	69.2	66	61.5	55.7	47.8	37.8	24.7			
-	P 7SV-350/7 T	3.5	2.57	-	2.84	-	5.1	83.5	80.7	78.8	74.7	69.4	62.6	53.9	42.7	27.5			
-	P 7SV-400/8 T	4	3	-	3.3	-	6	95.6	93.3	91.4	87.2	81.6	74.2	64.8	51.9	33.0			
-	P 7SV-450/9 T	4.5	3.31	-	3.81	-	6.5	108.5	106.6	105.1	101.0	95.0	87.2	76.6	62.6	39.5			
-	P 7SV-550/10 T	5.5	4	-	4.32	-	7.9	121.5	120.1	119.3	115.3	109.2	100.8	89.8	75.0	55.4			

PLUS 9SV

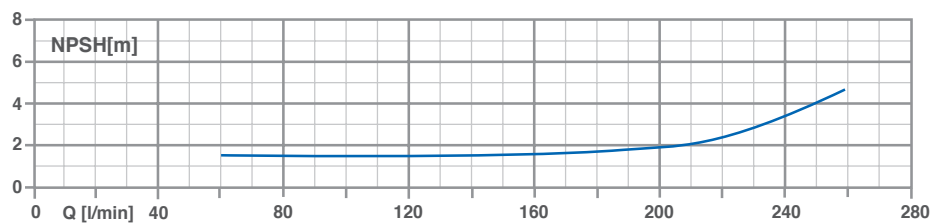
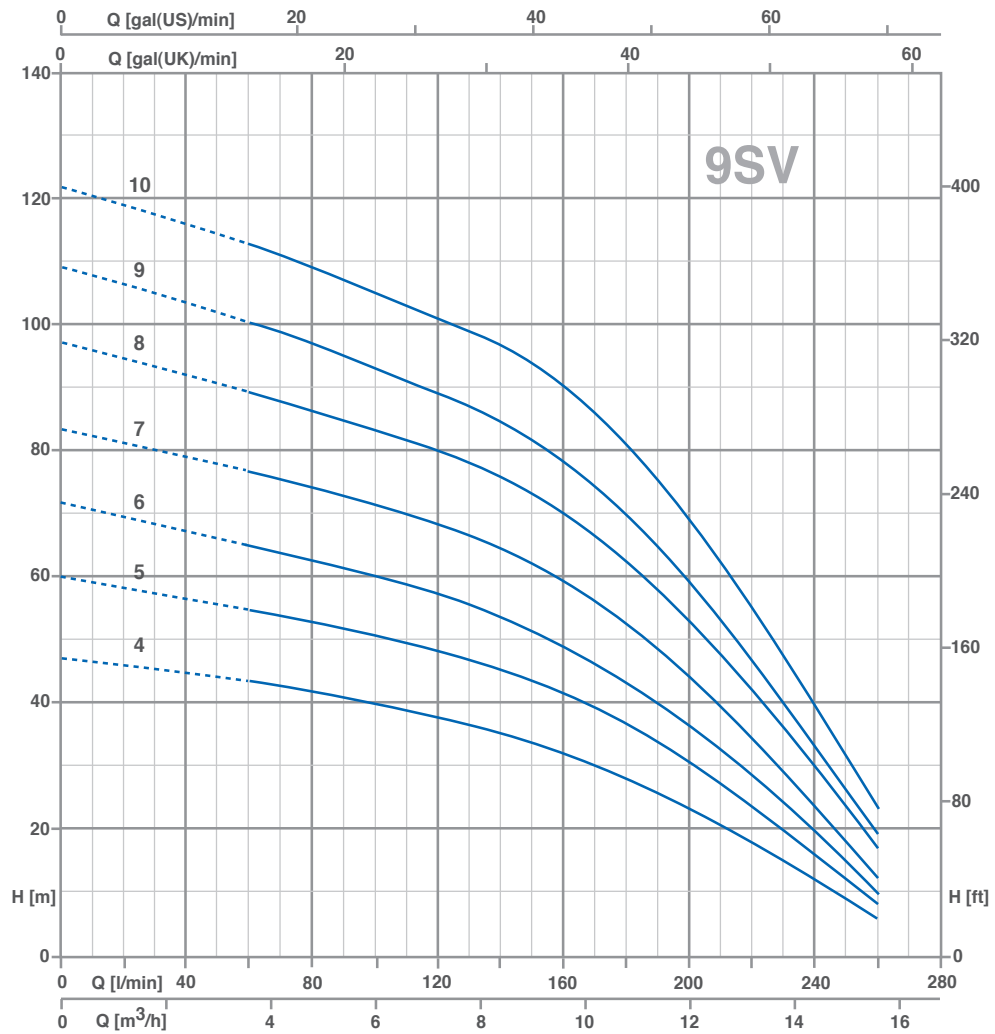

Dati tecnici / Technical data / Datos técnicos / Données techniques

TIPO / TYPE / MODELO / MODÈLE		P2		P1 (kW)		AMPERE		Q (m³/h - l/min)													
1~	3~	(HP)	(kW)	1~	3~	1~	3~	0	3.6	4.8	6	7.2	8.4	9.6	10.8	12	13.2	14.4	15.6		
								0	60	80	100	120	140	160	180	200	220	240	260		
								H (m)													
230 V - 50 Hz	230 / 400 V - 50 Hz					1x230V 50Hz	3x400V 50Hz	8.4	3.3	47.6	43.5	42.1	40.1	38.1	35.7	32.7	28.9	24.2	19	13.1	7.1
P 9SV-200/4	P 9SV-200/4 T	2	1.5	1.88	1.77	8.4	3.3	47.6	43.5	42.1	40.1	38.1	35.7	32.7	28.9	24.2	19	13.1	7.1		
P 9SV-250/5	P 9SV-250/5 T	2.5	1.85	2.36	2.23	10.8	4.3	60	54.8	53	51	48.2	45.4	42	37.3	31.6	25	18	10.6		
P 9SV-300/6	P 9SV-300/6 T	3	2.2	2.78	2.58	12.5	4.9	71.8	64.9	63	59.9	57	53.7	49.7	44.3	37	29.5	20.8	11.1		
-	P 9SV-400/7 T	4	3	-	3.13	-	5.8	83.3	76.7	74.9	71.8	68.3	64.6	59.9	53.5	44.8	35.9	25.7	14.3		
-	P 9SV-450/8 T	4.5	3.31	-	3.72	-	6.4	97.3	89.5	87.3	84	80.5	76.5	71.6	64.8	54.9	44	32.4	19.7		
-	P 9SV-500/9 T	5	3.7	-	4.11	-	7	109	100	97.6	93.6	89.5	85	79.4	71.6	60.1	48	34.9	21.9		
-	P 9SV-550/10 T	5.5	4	-	4.58	-	8.3	122	112.8	110.5	106.5	102.2	97.3	91.6	82.8	70.7	57.1	42.3	26.5		

PLUS 18SV

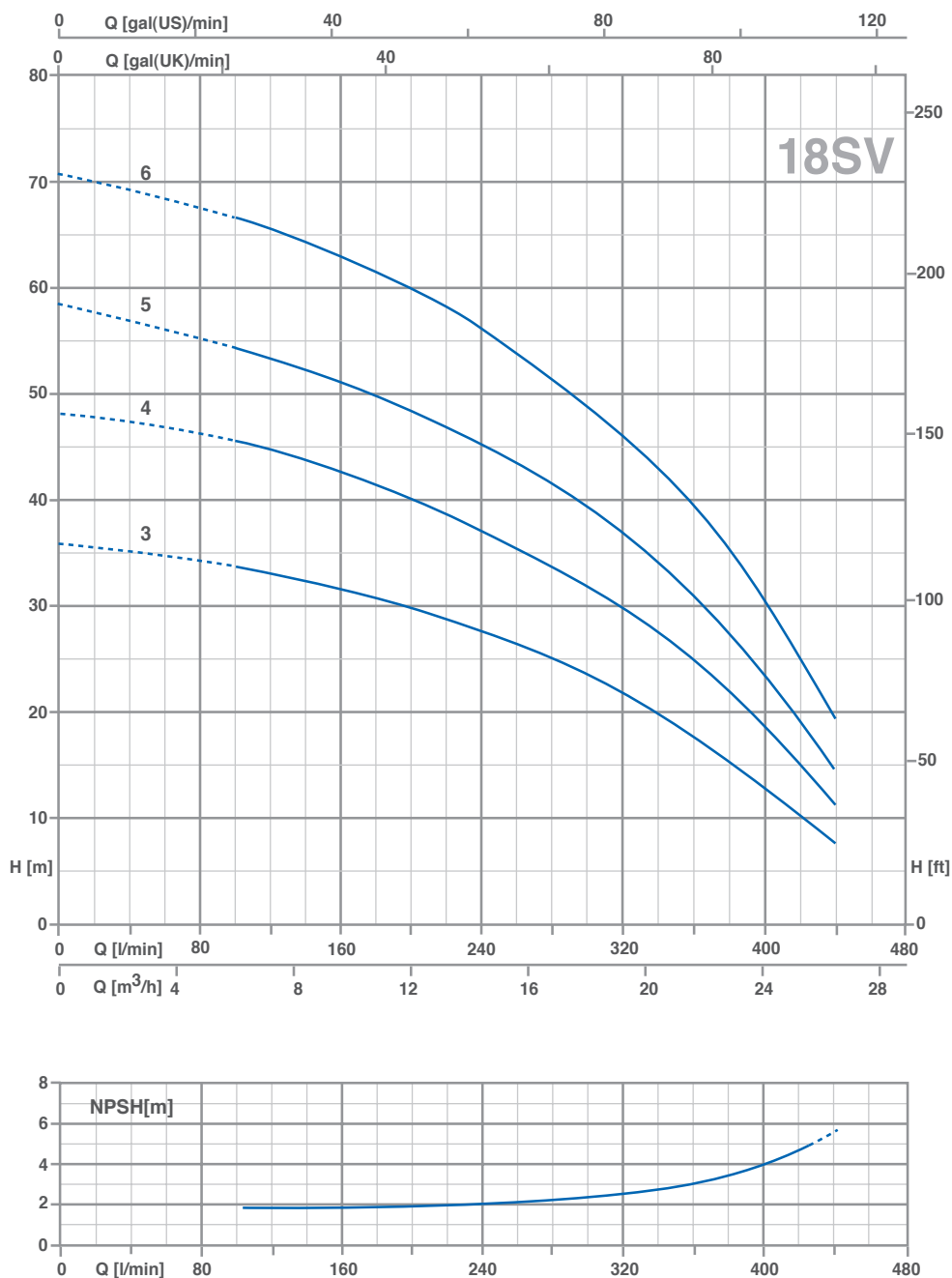

Dati tecnici / Technical data / Datos técnicos / Données techniques

TIPO/TYPE MODELO/MODÈLE	P2		P1 (kW)	AMPERE	Q (m³/h - l/min)																			
					3~																			
					0	6	7.2	8.4	9.6	10.8	12	13.2	14.4	15.6	16.8	18	19.2	20.4	21.6	22.8	24	25.2	26.4	
3~ 230 / 400 V - 50 Hz	(HP)	(kW)	3~	3x400V 50Hz	H (m)																			
P 18SV-250/3 T	2.5	1.85	2.29	4.4	35.7	33.1	32.3	31.3	30.4	29.4	28.4	27.4	26.3	25.1	24	22.8	21.4	19.6	17.8	15.4	12.9	10.2	7.5	
P 18SV-400/4 T	4	3	3.11	5.7	47.9	45	44	42.8	41.7	40.5	39.1	37.8	36.6	35.2	33.9	32.2	30.2	28	25.1	22.1	18.1	14.9	11.2	
P 18SV-450/5 T	4.5	3.31	3.79	6.7	58.1	54.3	53.1	51.8	50.4	49	47.4	45.9	44.3	42.7	41	39.2	37	34	30.8	26.9	23	18.7	14.3	
P 18SV-550/6 T	5.5	4	4.63	8.7	70.5	66.4	65	63.6	62	60.5	58.9	57.2	55.4	53.5	51.5	49.3	46.3	43.3	39.4	34.9	30.4	25	19.3	

PLUS 5SV - PLUS 7SV - PLUS 9SV - PLUS 18SV

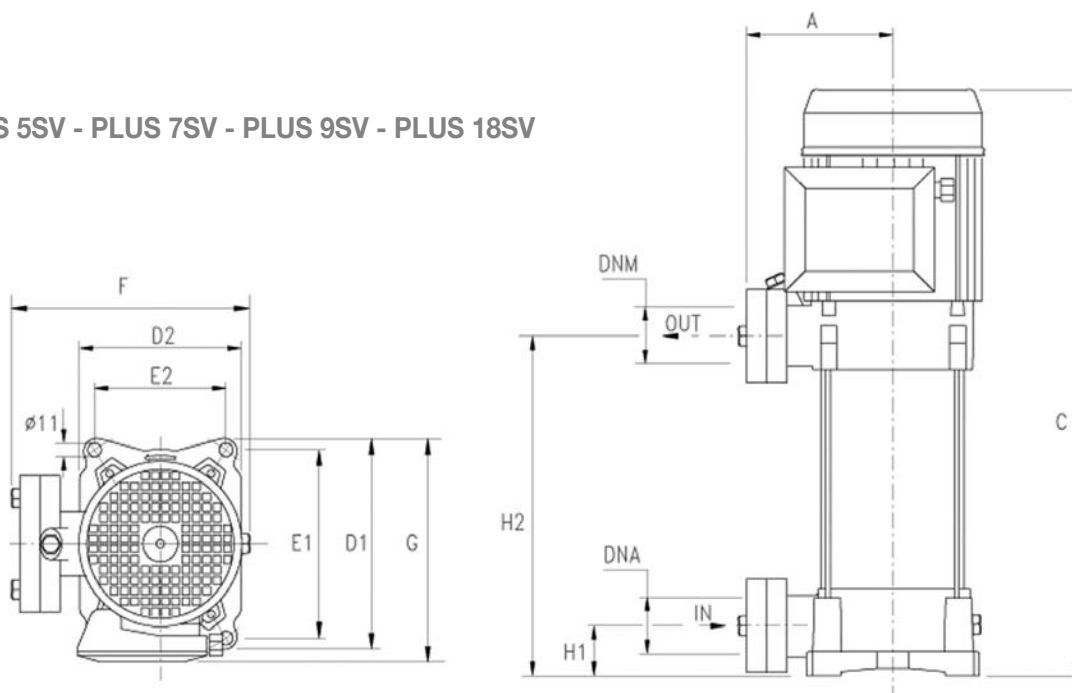

TIPO / TYPE MODELLO / MODÈLE	DIMENSIONI / DIMENSIONS / DIMENSIONES / DIMENSIONS (mm)										DNA	DNM
	A	C	D1	D2	E1	E2	F	G	H1	H2		
P 5SV-120/4	135	389	204	162	178.5	125	229	213	40	178	1"1/4 G	1"1/4 G
P 5SV-150/5	135	443	204	162	178.5	125	229	215	40	208.5		
P 5SV-180/6	135	467	204	162	178.5	125	229	215	40	232.5		
P 5SV-200/7	135	491	204	162	178.5	125	229	215	40	256.5		
P 5SV-250/8	135	515	204	162	178.5	125	229	215	40	280.5		
P 5SV-280/9	135	M 584 T 539	204	162	178.5	125	229	M 230 T 215	40	304.5		
P 5SV-300/10	135	M 608 T 563	204	162	178.5	125	229	M 230 T 215	40	328.5		
P 5SV-350/11	135	626	204	162	178.5	125	229	230	40	352.5		
P 7SV-180/4	135	419	204	162	178.5	125	229	215	40	184.5		
P 7SV-250/5	135	443	204	162	178.5	125	229	215	40	208.5		
P 7SV-300/6	135	M 512 T 467	204	162	178.5	125	229	M 230 T 215	40	232.5		
P 7SV-350/7	135	552	204	162	178.5	125	229	230	40	256.5		
P 7SV-400/8	135	576	204	162	178.5	125	229	230	40	280.5		
P 7SV-450/9	135	633	204	162	178.5	125	235	250	40	304.5		
P 7SV-550/10	135	657	204	162	178.5	125	235	250	40	328.5	1"1/2 G	1"1/4 G
P 9SV-200/4	135	443	204	162	178.5	125	229	215	40	208.5		
P 9SV-250/5	135	473	204	162	178.5	125	229	215	40	238.5		
P 9SV-300/6	135	M 548 T 503	204	162	178.5	125	229	M 230 T 215	40	268.5		
P 9SV-400/7	135	578	204	162	178.5	125	229	230	40	298.5		
P 9SV-450/8	135	641	204	162	178.5	125	235	250	40	328.5		
P 9SV-500/9	135	671	204	162	178.5	125	235	250	40	358.5		
P 9SV-550/10	135	701	204	162	178.5	125	235	250	40	388.5		
P 18SV-250/3 T	135	451	204	162	178.5	125	229	215	50	213.5		
P 18SV-400/4 T	135	534	204	162	178.5	125	229	230	50	251		
P 18SV-450/5 T	135	605	204	162	178.5	125	235	250	50	288.5		
P 18SV-550/6 T	135	642	204	162	178.5	125	235	250	50	326		